

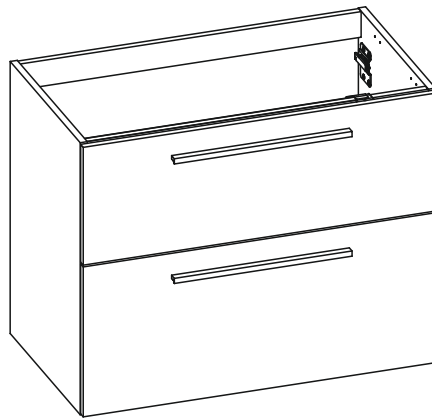

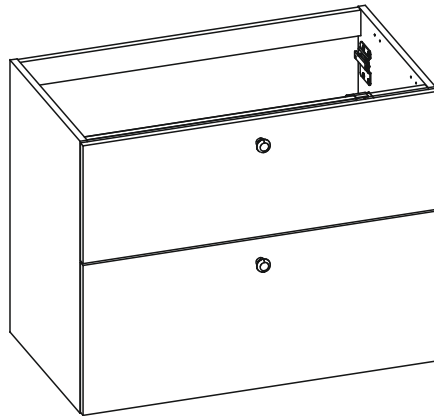

60 2DR
80 2DR
100 2DR

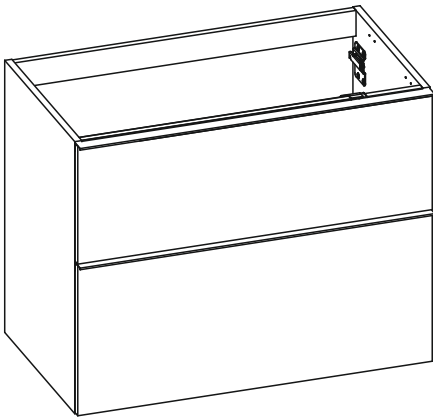
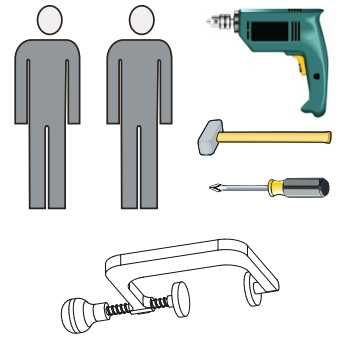

Karta Gwarancyjna
Warranty card
Garantiekarte

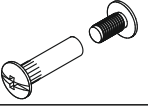
R8	X
	
x 4	x 1
P0	P15
	
x 6	x 2

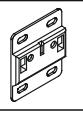
EN Caution: Always use appropriate fixings to suit your type of wall. / **ES ¡Atención!** Use siempre las fijaciones apropiadas dependiendo del tipo de pared. / **FR ! Attention:** Utilisez toujours une fixation adaptée à votre type de mur. / **DE Achtung:** Bitte verwenden Sie für ihr Mauerwerk geeignetes Befestigungsmaterial. / **IT Attenzione:** I fissaggi devono essere scelti a seconda del tipo di muro. / **PL Uwaga:** Stosuj mocowania ścienne odpowiednie do rodzaju ściany. / **NL Waarschuwing:** gebruik altijd bevestigingsmaterialen die geschikt zijn voor uw wand-type. / **BG Внимание:** Винаги използвайте подходящи крепежни елементи, според вида на стената. / **RU Внимание:** Всегда используйте подходящий для Вашего типа стены крепеж. / **GR Προσοχή:** Για την καλύτερη εγκατάσταση προτείνουμε να χρησιμοποιείτε πάντα τα κατάλληλα στηρίγματα. / **CZ Pozor:** Použijte prosím takové montážní prvky, které odpovídají typu stěny. / **RO Atenție:** Elementele de fixare trebuie să fie alese în funcție de tipul de perete. / **LT Įspėjimas:** Visada naudokite tinkamus tvirtinimo elementus, atitinkančius jūsų sienos tipą. / **EE Ettevaatus:** Kasutage alati sobivaid kinnitusi, mis sobivad teie seinatüübiga. / **LV Uzmanību:** Vienmēr izmantojiet piemērotus stiprinājumus, kas atbilst jūsu sienas tipam. / **CRO Napomena:** Uvijek koristite odgovarajuće pričvršne elemente koji odgovaraju vašoj vrsti zida. / **RS Oprez:** Uvek koristite odgovarajuća pričvršćivanja koja odgovaraju vašem tipu zida. / **HU Figyelem:** Mindig a faltípusnak megfelelő rögzítést használjon. / **SLO Pozor:** Vedno uporabite ustrezne pritrdilne elemente glede na tip stene.

01.

x8

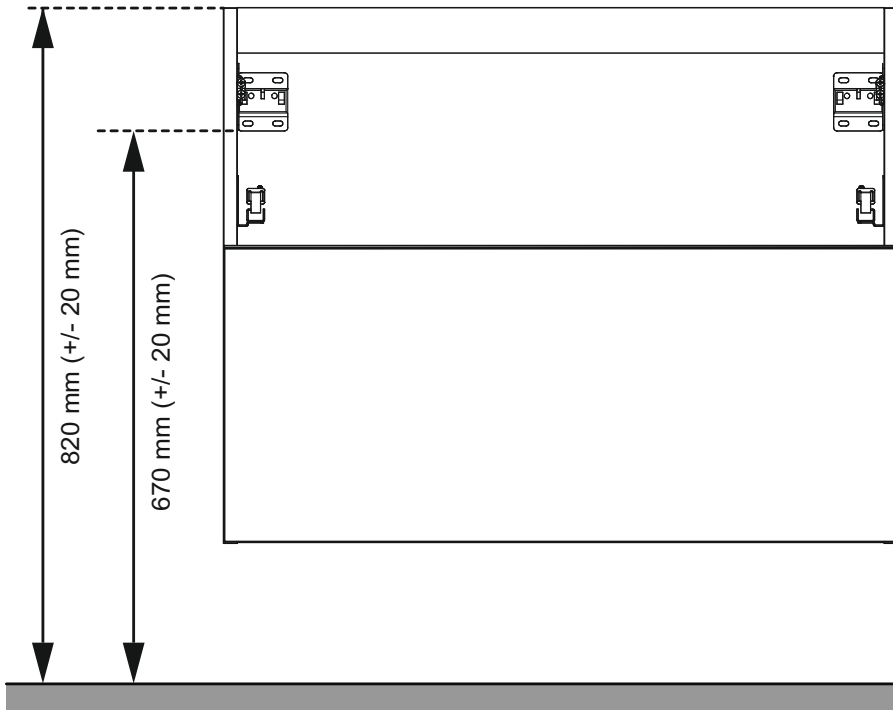

02.

x8

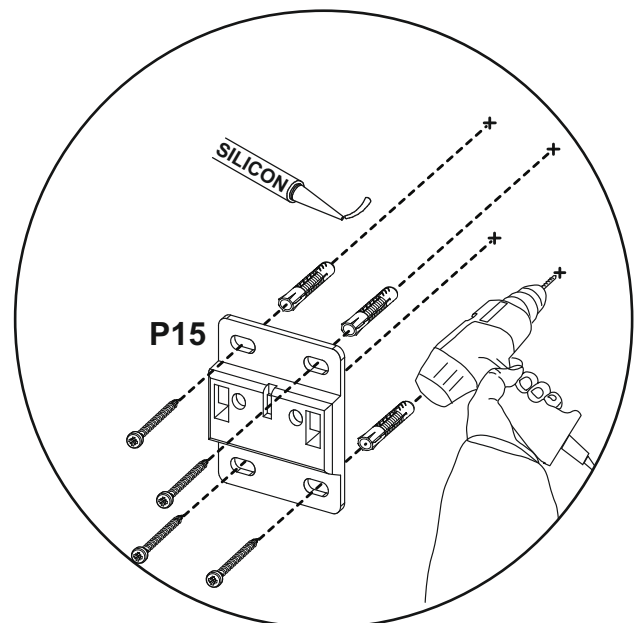
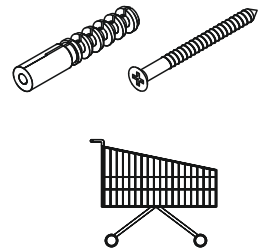
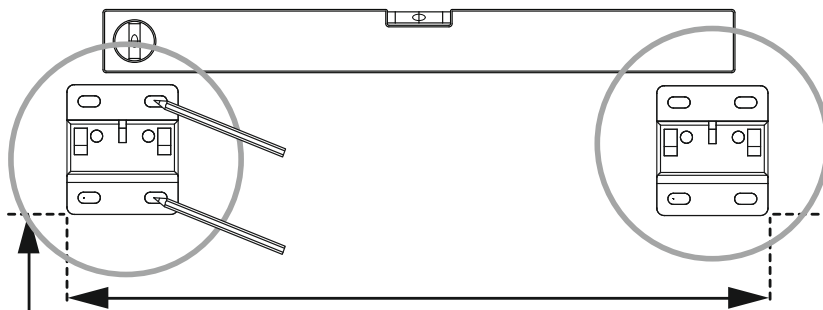

03.

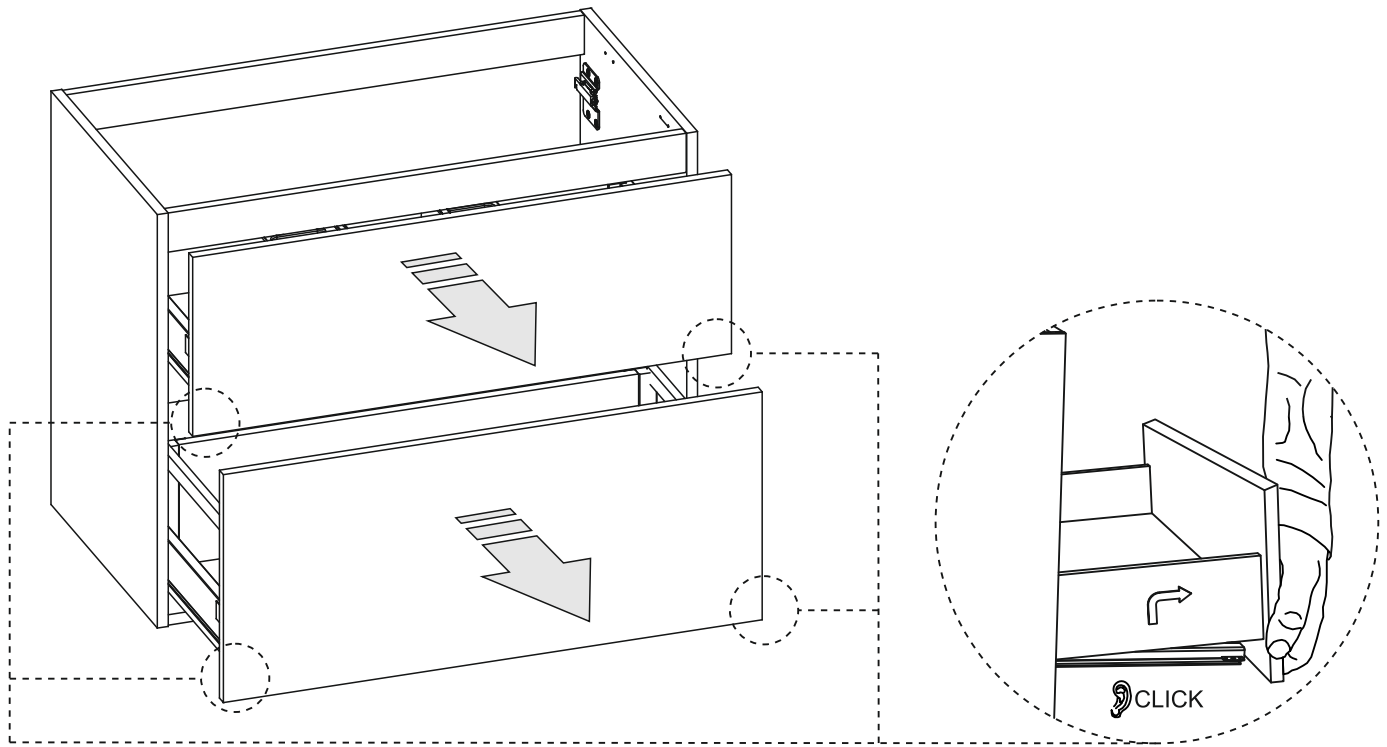

04.

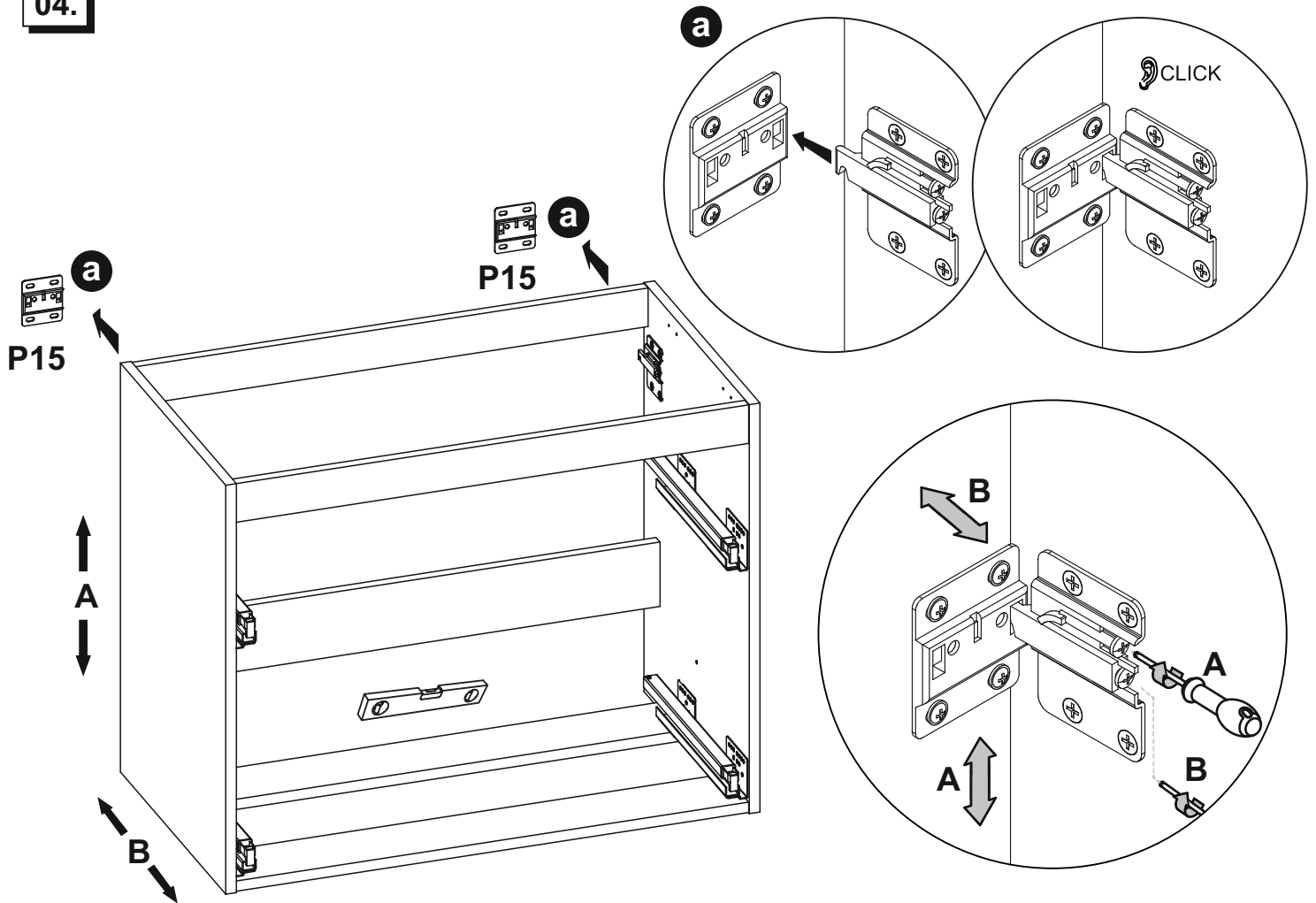

05.

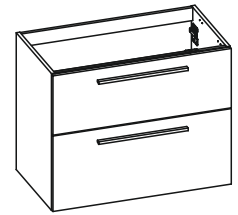
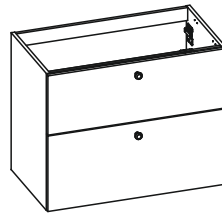
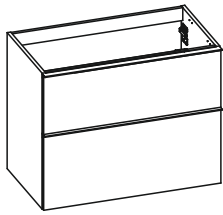
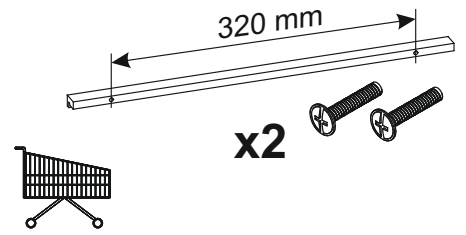
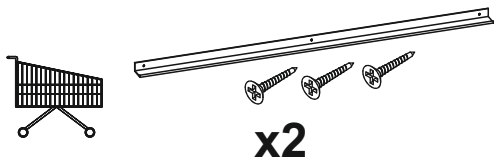

06.



07.

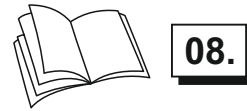

08.

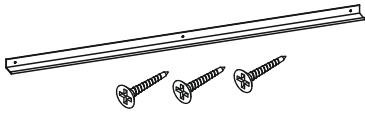
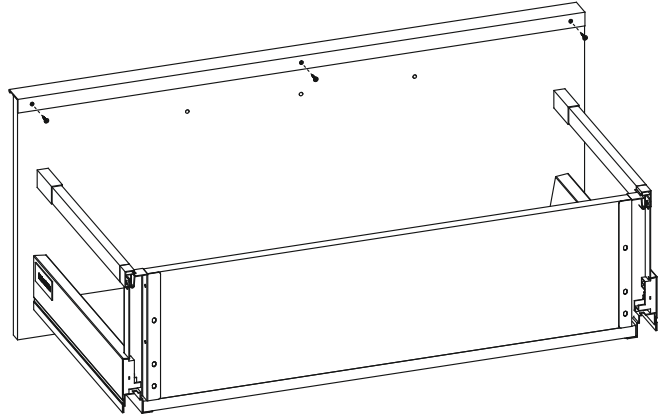
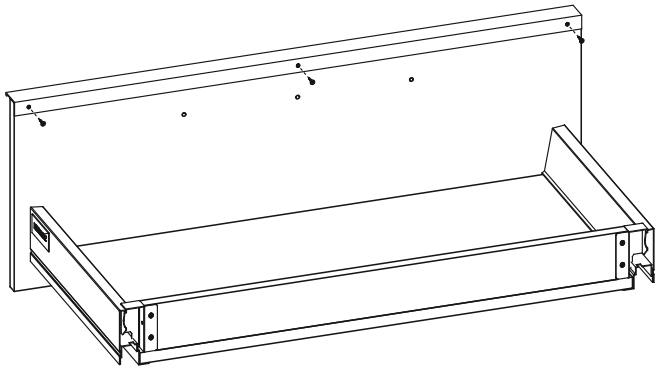

x2

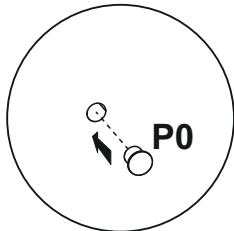
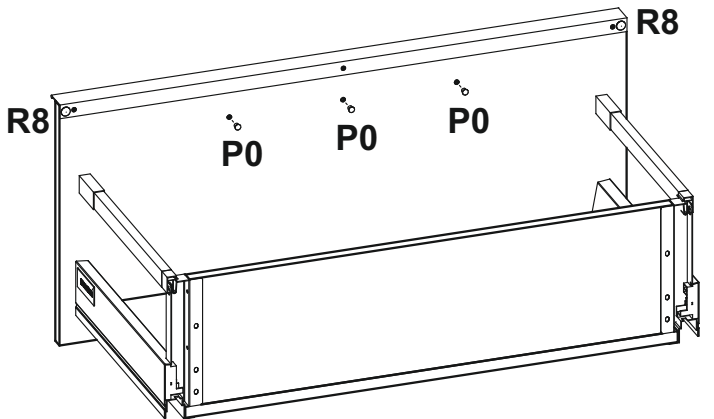
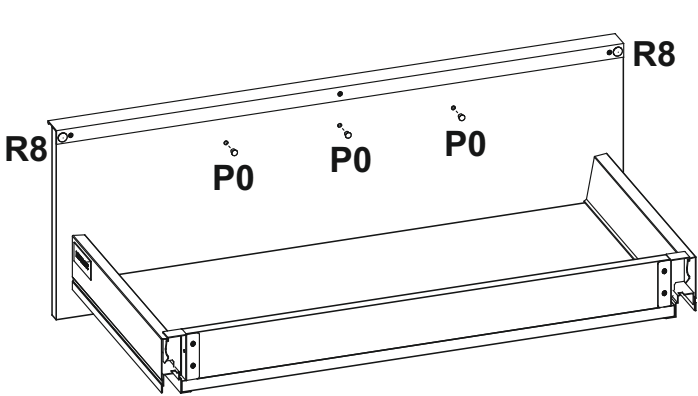
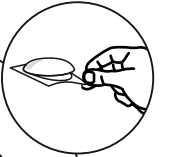
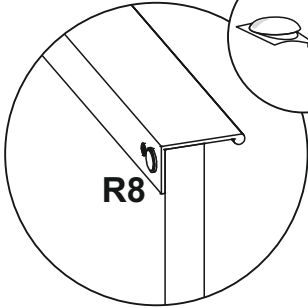
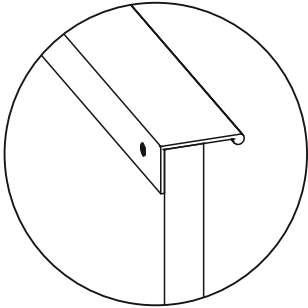
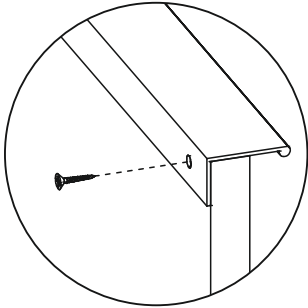
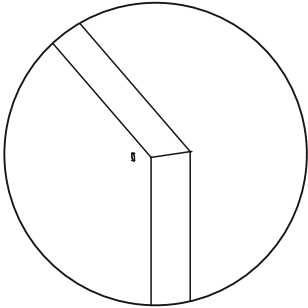

07.

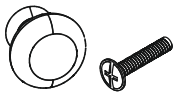
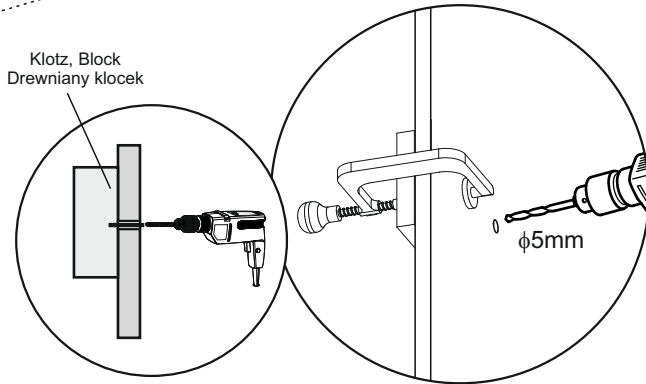
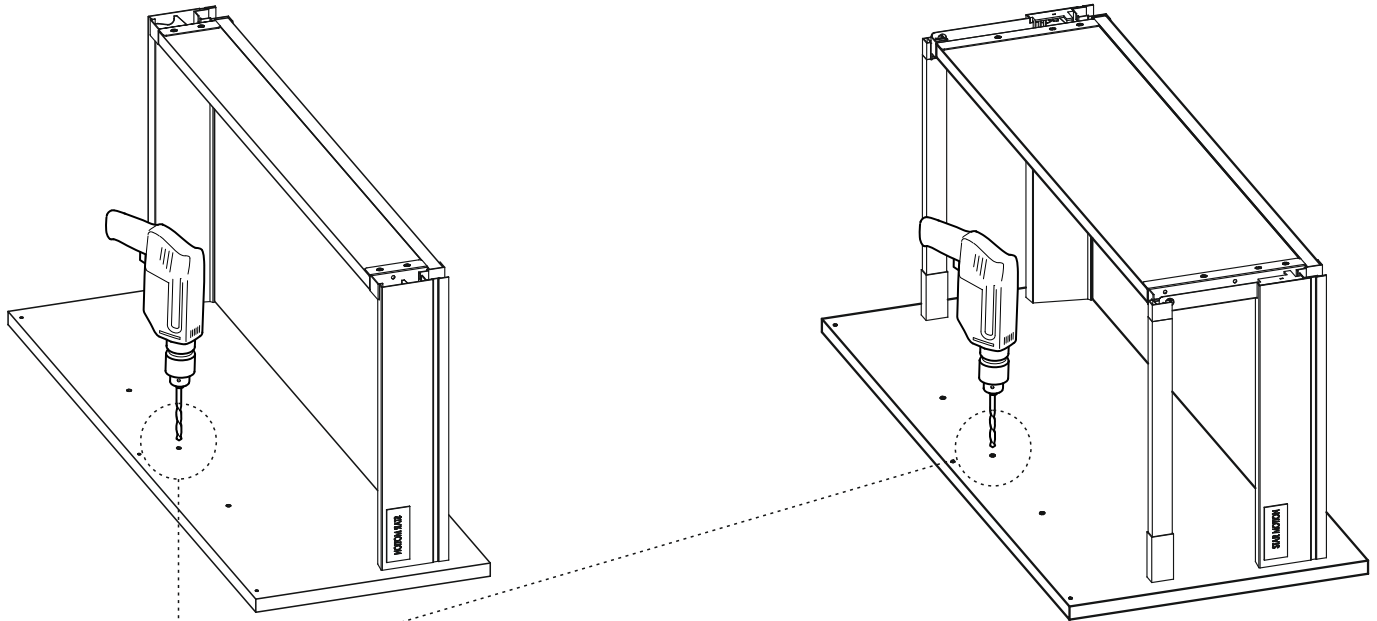

x2

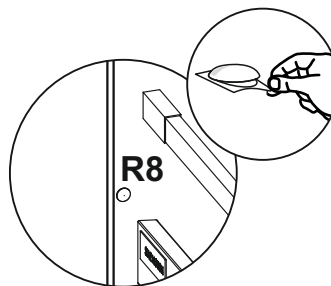
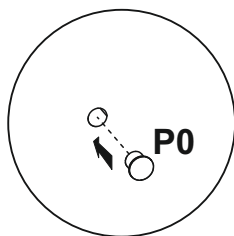
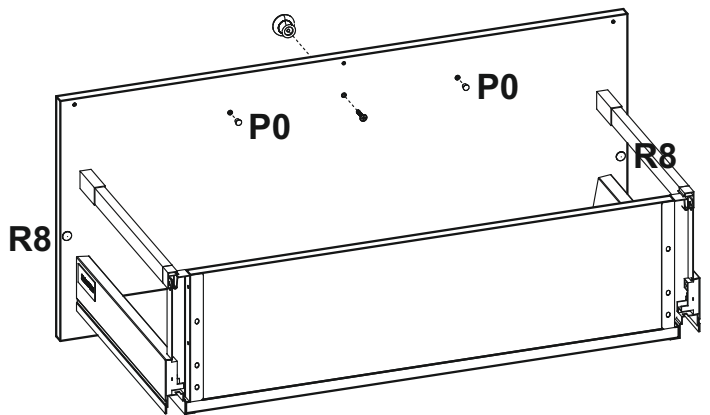
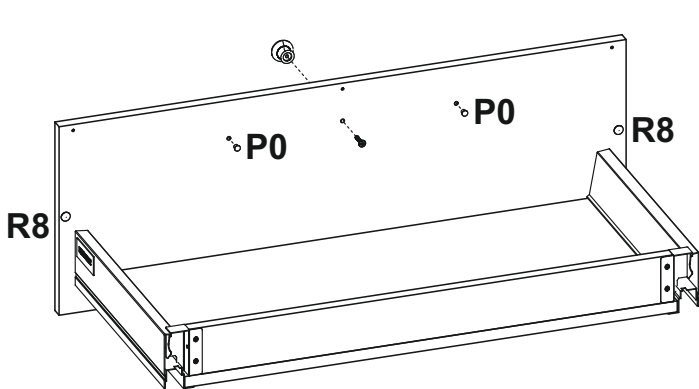

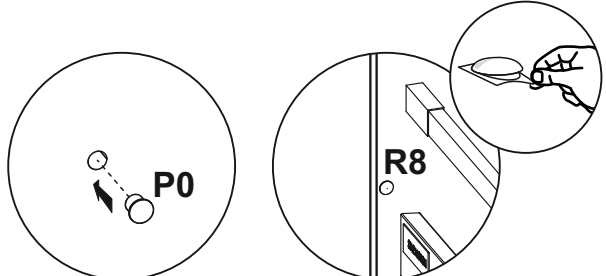
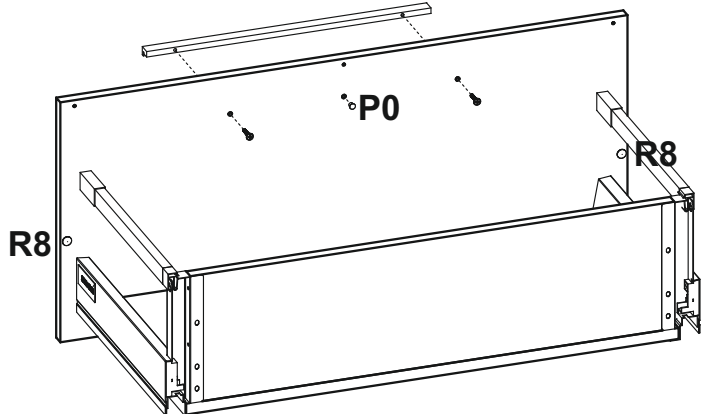
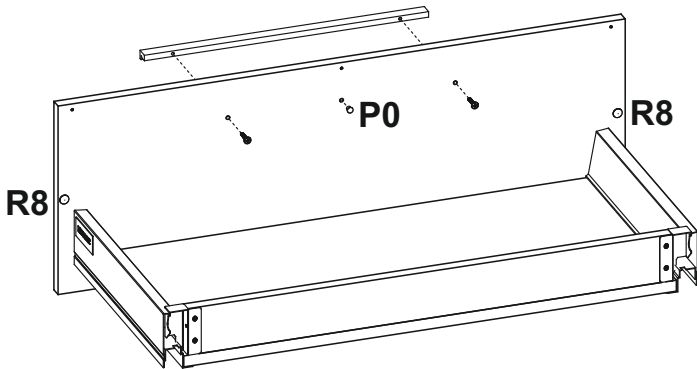
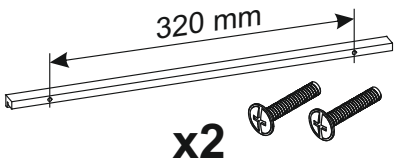
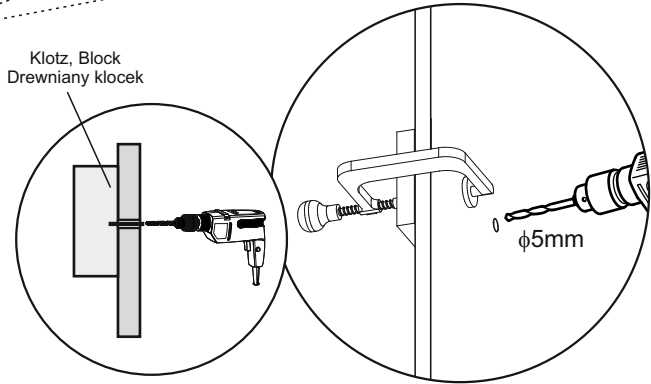
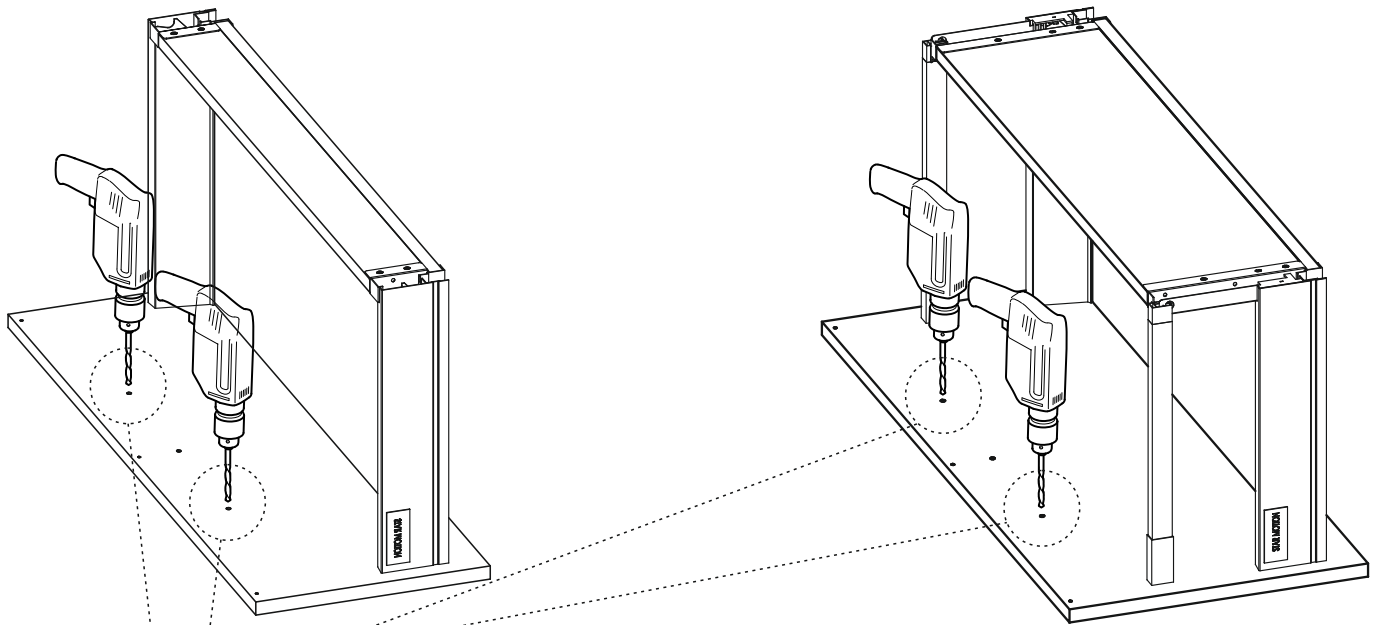

09.

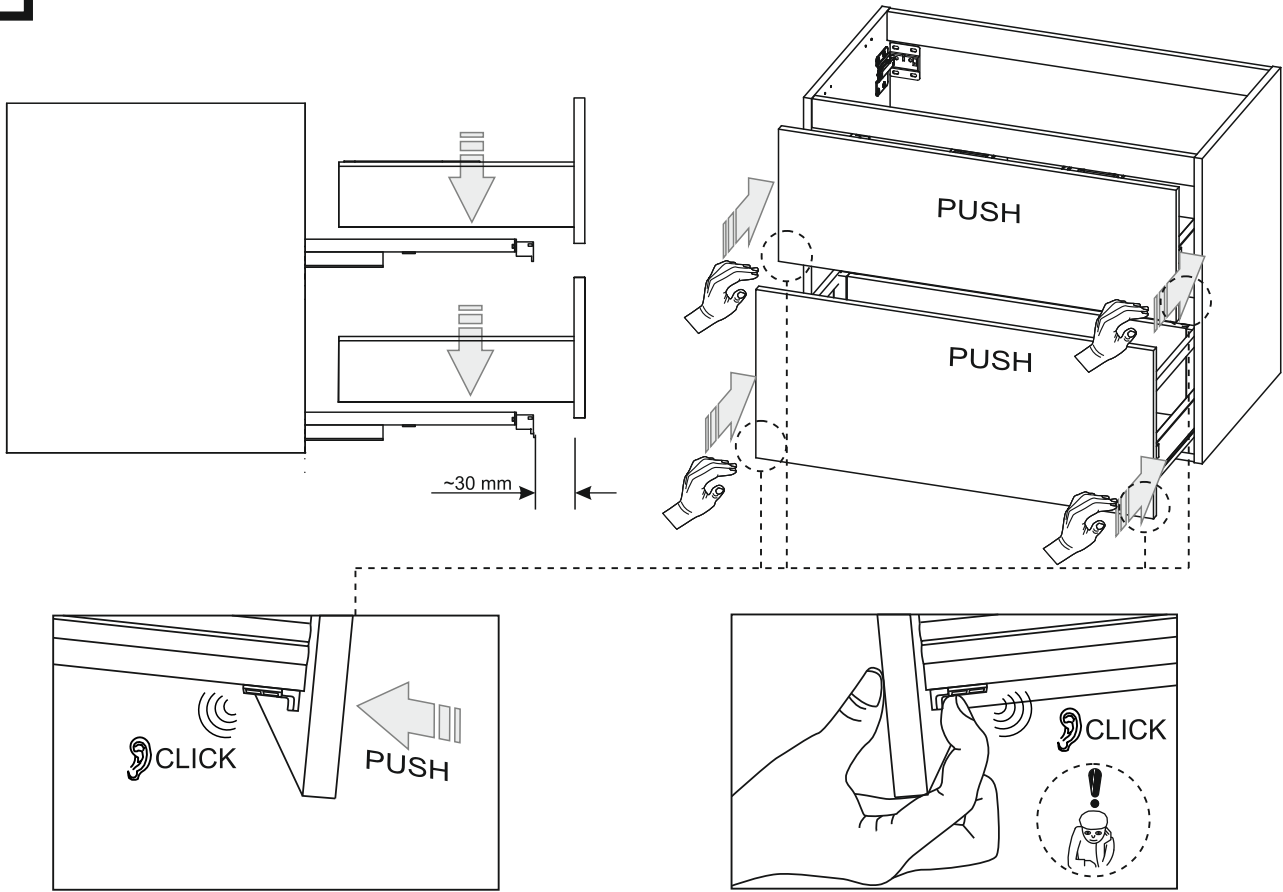

10.

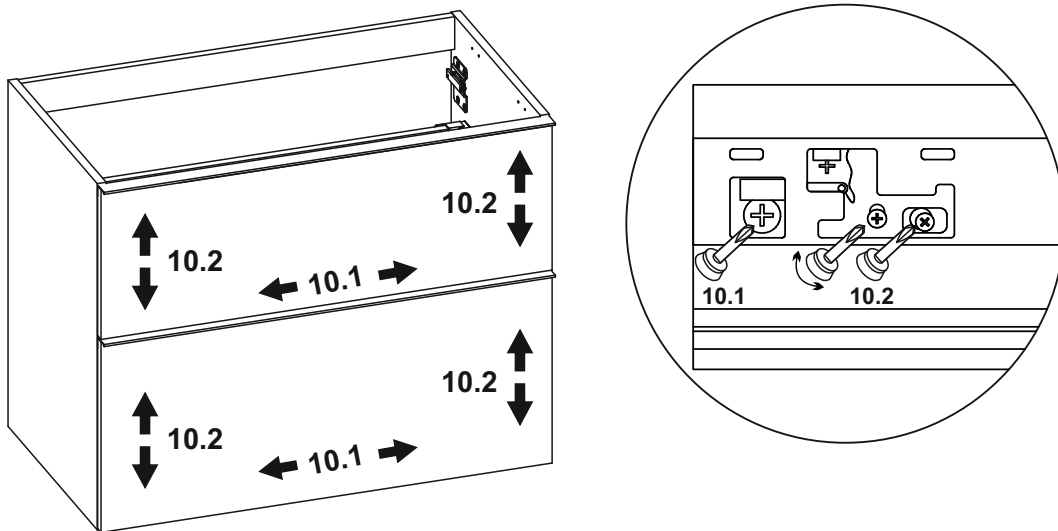

11.

